

FIT-IPL-R Specifications^(*) :

Fit-IPL-R		
Parameter	Power (rEP)	Energy (Sin)
Maximum Measurable Power (W)/Energy (J)	100	350
Minimum Measurable Power @ ±3% Accuracy (W/J)	2	7
Absolute Minimum Measurable Power/Energy (W/J)	1	3,5
Maximum Spot Size (mm) (W x H)	18x60	
Power density damage threshold @ full scale at 1064 nm (YAG laser wavelength) (W/cm ²)	10000	
Repeatability (W/J)	± 1%	± 3%
ADC Resolution (W/J)	± 0.12	± 0.45
Display Resolution (W/J)	0.01	0.1
Measurement Accuracy ⁽¹⁾	±3%	±5%
Maximum allowable sensor head temperature (°C)	70	
Time to measure and display data (s)	10	-
Waiting time between 2 energy measures (s)	-	25
Power consumption in On status (mW)	26	
Power consumption in Off status (µW)	25	
Power supply (2x AA Batteries) (V)	3	
Continuous operation without battery replacement (h)	200	
Operating temperature range (°C)	da +10 a +40	
Storage temperature range (°C)	da -10 a +60	
Weight (body) (g)	336	
Weight (sensor with cable) (g)	178	
Size (head) LxWxH (mm)	60x100x26	
Size (body) LxWxH (mm)	95x71x46	

(1) Individually compared against a NIST/PTB reference.

*All specifications subject to change without notice)

To maintain performance and specifications, LaserPoint recommends to calibrate the probes once a year.

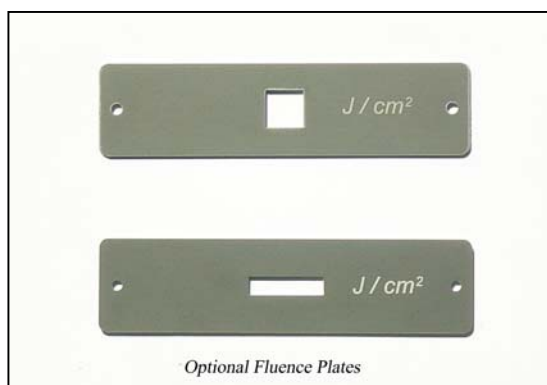
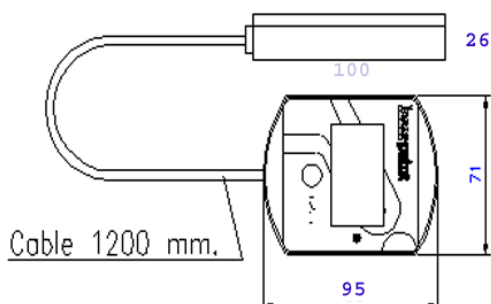

Ordering Information (please add all codes when ordering)

Item	Code
Digital Power/Energy Probe (100 W - 350 J)	Fit-IPL-R
Option: Plate with high precision laser cut 1cm ² bore for fluence (J/cm ²) measurement . Available sizes 1x1 cm ² and 2x 0,5 cm ² .	Fluence Plate
Carrying box	FitBox



Via Burona, 51 - Vimodrone (Milano) – ITALY

Tel. +39 02 27 40 02 36 ; Fax +39 02 25 02 91 61 ; web: www.laserpoint.eu